

### PSTV

The **PSTV** probe is a hermetically sealed reed float switch which signals the presence of liquids. It is designed to fit into a double-walled tank's 1½" standpipe. The probe resets immediately after the liquid is removed.

The unique design of the **PSTV** probe eliminates the need for additional power at the probe.

A **PSTV** probe is available for the PAL-AT® or LiquidWatch® systems

The **PSTV** probe can easily be connected to a PAL-AT® cable "sensing string" providing increased utilization of the PAL-AT capabilities. Each assembly includes a probe integrator with 60 ft (18 m) of jumper cable to connect to the sensing string, and 20 ft (6 m) of lead cable to attach the float switch to the probe integrator.

The **PSTV** probe for Liquid-Watch includes the probe adapter that is incorporated in the 20 ft (6 m) long probe lead wire. Additional lead wire is used if necessary.

#### PAL-AT NOTE:

- A"-S" probe must be connected in the first 5,000 ft (1,500 m) of sensing string.
- A"-L" probe must be connected more than 5,000 ft (1,500 m) from the PAL-AT panel.

#### PART NUMBERS:

<u>PAL-AT:</u>		<u>LiquidWatch:</u>	
PSTV-S	8027624	PSTV-LW	8027903
PSTV-L	8027920		
JBXHTM	8027883		

JBXHTM high temperature modification replaces polyester junction box with a fiberglass box

#### PROBE TECHNICAL DATA:

- Operating Temperature: -40°F to 176°F (-40°C to 80°C)
- Diameter: 1.32" (34 mm)
- Extension Length (max): 15 ft (4.5 m)
- Lead Length: 20 ft (6 m)
- Activation Level: Water: (S.G. = 1.0) .88" (22 mm)  
Oil: (S.G. = .75) 1.0" (25 mm)
- Stem: Brass
- Float: Buna-N
- Housing: CPVC
- Special Materials Available on Request

#### JUNCTION BOX: (PAL-AT ONLY)

- NEMA 4X (IP66) 10" x 8" x 4" (250 mm x 200 mm 100 mm)
- Maximum Temperature: 150°F (65°C)
- Maximum Temperature of Probe Integrator 140°F (60°C) in Hazardous Areas
- JBXHTM enclosure available for maximum operating temperature of 176°F (80°C)

#### APPLICATIONS:

- Interstitial Double Wall Tanks • Sumps
- Manways • Tank Monitoring Wells
- High / Low Level Alarms

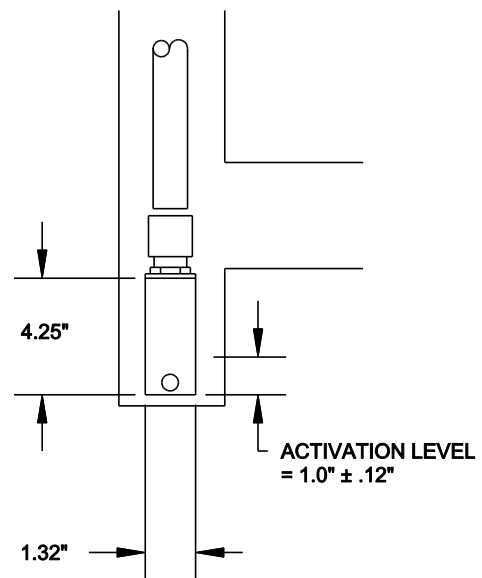

**PSTV FLOAT SWITCH  
ASSEMBLY DETAIL**

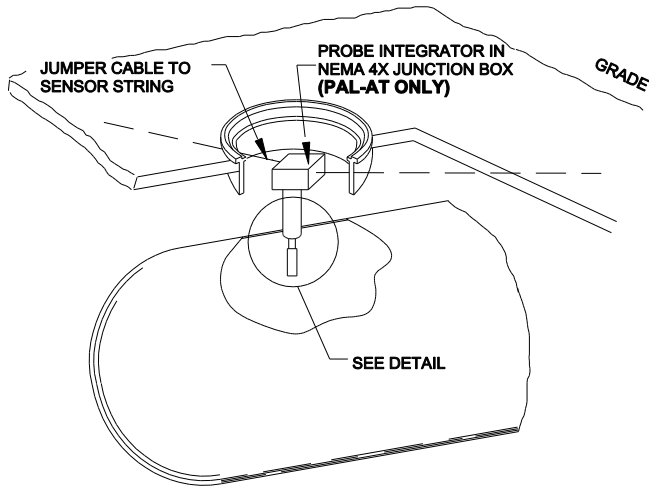

**PTHL**

The **PTHL** probe is a hermetically sealed reed float switch which signals the presence of liquids. It is designed to be a high level alarm for single and double-walled tanks. Typically,

the probe is located to activate when the tank is 90% full. The probe resets immediately after the liquid drops below the activation level.

The unique design of the PTHL probe eliminates the need for additional power at the probe.

A **PTHL** probe is available for the PAL-AT® or LiquidWatch® systems:

The **PTHL** probe can easily be connected into a PAL-AT cable "sensing string" providing increased utilization of the PAL-AT capabilities. Each assembly includes a probe integrator with 60 ft (18 m) of jumper cable to connect to the sensing string, and 20 ft (6 m) of lead cable to attach the float switch to the probe integrator.

The **PTHL** probe for LiquidWatch includes the probe adapter that is incorporated in the 20 ft (6 m) long probe lead wire. Additional lead wire is used if necessary.

**PAL-AT NOTE:**

- A"-S" probe must be connected in the first 5,000 ft (1,500 m) of sensing string.
- A"-L" probe must be connected more than 5000 ft (1500 m) from the PAL-AT panel.

**PART NUMBERS:**

<u>PAL-AT</u>		<u>LiquidWatch:</u>	
PSTV-S	8027633	PTHL-LW	80237906
PSTV-L	8027970		
JBXHTM	8027883		

JBXHTM high temperature modification replaces polyester junction box with a fiberglass box.

**PROBE TECHNICAL DATA:**

- Operating Temperature: -40°F to 176°F (-40°C to 80°C)
- Diameter: 1.32" (34 mm)
- Extension Length (max): 5 ft (1.5 m)
- Lead Length: 20 ft (6 m)
- Activation Level: Water: (S.G. = 1.0) .88" (22 mm)  
Oil: (S.G. = .75) 1.0" (25 mm)
- Stem: Brass
- Float: Buna-N
- Extension Housing: CPVC
- Special Materials Available on Request

**JUNCTION BOX: (PAL-AT ONLY)**

- NEMA 4X (IP66) 10" x 8" x 4" 250 mm x 200 mm 100 mm
- Maximum Temperature: 150°F ° (65°C)
- Maximum Temperature of Probe Integrator 140°F (60°C) in Hazardous Areas
- JBXHTM enclosure available for maximum operating temperature of 176°F (80°C)

**APPLICATIONS:**

- Interstitial Double Wall Tanks • Sumps
- Manways • Tank Monitoring Wells
- High / Low Level Alarms

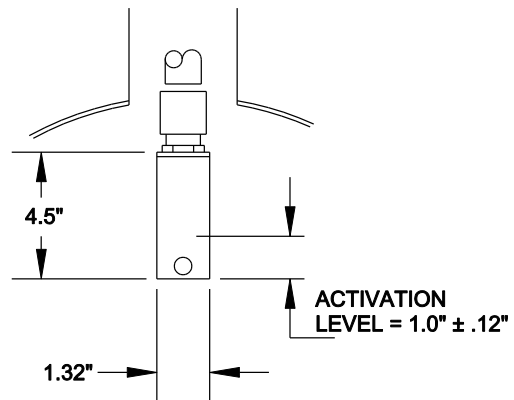

**PTHL FLOAT SWITCH ASSEMBLY DETAIL**

The information contained in this document is subject to change without notice. PermaAlert, a Division of PERMA-PIPE, Inc., believes the information contained herein to be reliable, but makes no representations as to accuracy or completeness. PermaAlert offers a sole and exclusive one year warranty as is stated in the Standard Terms and Conditions of Sale for these products. In no event will PermaAlert be liable for any indirect, incidental or consequential damages.